

## An Exciting Time for Graduate Education at UCSD

By Kim E. Barrett

### Dean of the Graduate Division

Few, if any, of our emeriti would take issue with the idea that the lifeblood of any great research university lies in its graduate students. Indeed, who are in a better position to understand the contributions made by our graduate students to our research output, societal impact, and prestige amongst external audiences? UCSD has done amazing things in the period of a little more than fifty years since our institution was founded, and those great things include the accomplishments of our graduate students and graduate alumni.

However, one area where we fall short of the competition is in the number of graduate students we have been able to enroll, both in absolute numbers and in terms of the percentage they represent of our student body. While numbers have inched upwards since I became Dean of the Graduate Division in 2006, now exceeding 4500 (exclusive of medical and pharmacy students, as well as those in self-supporting programs), their percentage has remained stubbornly around 16% for a number of years, driven in part by a previously unanticipated growth in the non-resident undergraduate



population. Competitor public research universities, including sister UC campuses, often have a graduate population that exceeds 30% of the total student body. In some private comparators, the percentage may be as high as 60%. Many have opined that the relative paucity of graduate students on our campus is an Achilles heel that ultimately will stall our rise in the rankings.

Certainly, there is no shortage of talented individuals from all over the world seeking to pursue their graduate education in La Jolla. At the time of writing, we are in the midst of the admissions season. An astonishing 18,035 applications have been lodged for fall 2015,

which exceeds last year's year-to-date total by 1,630. Two departments (Electrical and Computer Engineering and Computer Science and Engineering) combine for more than 6,000 of that total, but almost all departments and programs have a sufficient, and growing, applicant pool to allow for an extremely competitive admissions process.

It is not surprising that our programs are so popular. The last National Research Council rating of doctoral programs (2010) indicated that a majority of our programs can be considered in the top 20 nationwide, with five programs achieving ratings within the top four nationally (Table 1). Furthermore, we have implemented innovative masters programs, some of

*cont. on page 2* →

### ◆◆◆ Inside ◆◆◆

An Exciting Time for Graduate Education at UCSD .....	1
UCSD Singled Out for Bold Improvements in Energy...	3
Remembering Mel Spiro.....	4
Joe Gusfield, Founding Chair of Sociology .....	5
Anecdote .....	7
Mark your calendar .....	8

which have followed a self-supporting model (i.e., devoid of any state support) to train the next generation of practitioners in a variety of fields, such as Medical Device Engineering, Marine Biodiversity and Conservation, and Clinical Research.

These programs also offer working professionals the opportunity to move up in their chosen field. They fulfill the University's mission to impart local impact by translating its research advances to state-of-the-art educational offerings. Some national observers have opined that the "masters is the new bachelors." Certainly, the increase in technical complexity of many careers mandates a much

*We consider that diversity across numerous dimensions is an essential element for a thriving graduate student population that can devise creative solutions to pressing problems.*

higher level of educational preparation. Chancellor **Pradeep Khosla** and Executive Vice Chancellor (EVC) **Suresh Subramani** have also recently put financial incentives in place that should encourage departments to increase enrollments to existing master's programs, or to start new ones.

The character of our graduate student population is changing in other ways as well. First, it is becoming increasingly international. Two years ago, the Chancellor and

EVC launched the Graduate Student Growth and Excellence Initiative. This scheme will rebate non-resident tuition paid for doctoral students in their first, second or third year of study, with the funds intended to increase the competitiveness of stipend offers, provide some relief to faculty who support students on their research grants and/or increase enrollments.

The program has greatly enhanced the ability of departments to shoulder the added expense of international students, allowing them to admit the best applicants regardless of their national origin. In 2012, 27% of our student body was international. This year, that proportion has risen to 30%, and fully 40% of entering students in fall 2014 were international. Second, our domestic students are also becoming increasingly diverse, with more than 10% of our overall student body now comprised of students from minority groups that traditionally have been under-represented in graduate education (URM). We consider that diversity across numerous dimensions is an essential element for a thriving graduate student population that can devise creative solutions to pressing problems.

Clearly we still have a way to go before our student body reflects the ethnic diversity of the State of California, but it is encouraging to note that when URM students apply to our programs they are admitted at rates that at least equal, and in many cases exceed, the admission rates of

majority students, and once admitted, they accept our offers at rates that again are comparable to those of majority students. Similarly, and bucking a national trend, students from URM groups complete PhD studies at UCSD at rates comparable to their majority peers. Our challenge is to attract sufficient numbers of diverse applicants, a constant preoccupation of the Graduate Division that we are approaching with a variety of strategies. For example, under the banner of the Frontiers of Innovation Scholars Program, a suite of new initiatives supporting the Chancellor's strategic plan, we are greatly expanding our Summer Training Academy for Research Success (STARS).

STARS is reaching out to talented undergraduates at historically black colleges and universities, Hispanic-serving institutions

(including many campuses in the California State University system) and local community colleges to offer a residential, mentored summer research experience and other activities that will prepare them well for graduate school. In this way, we hope not only to expand the pool of applicants from URM groups, but also their interest in UCSD specifically.

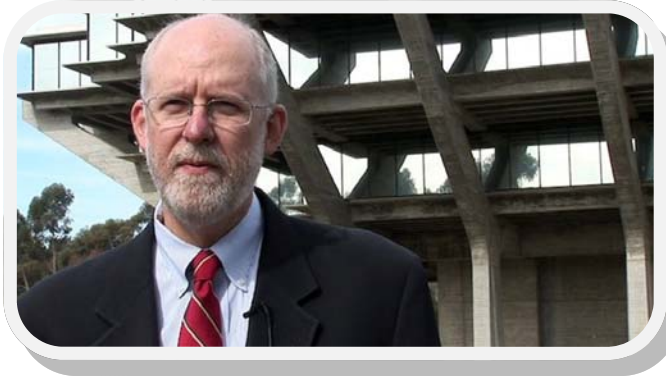

**Table 1: UCSD Doctoral Programs rated in the top four nationally by the National Research Council**

- **Bioengineering**
- **Biological Sciences**
- **SIO**
- **Biomedical Sciences**
- **Neurosciences**

# UCSD is Singled Out for Bold Improvements in Energy

In a Special Report on Energy and Technology, **The Economist Magazine** (January 17, 2015) notes UCSD's pioneering accomplishments – thanks to the leadership of **Steve Relyea** and **Gary Matthews**:



Steve Relyea



Gary Matthews

Some organizations, such as military bases, may have specific reasons to want to be independent of outside suppliers, but for most of them the main motive is to save money. The University of California, San Diego (UCSD), for example, which until 2001 had a gas plant mainly used for heating, changed to a combined-heat-and-power (CHP) plant which heats and cools 450 buildings and provides hot water for the 45,000 people who use them. The system generates 92% of the campus's electricity and saves \$8m a year. As well as 30 MW from the CHP plant, the university has also installed more than 3 MW in solar power and a further 3MW from a gas-powered fuel cell. When demand is low, the spare electricity cools 4m gallons (15m litres) of water for use in the air-conditioning—the biggest load on the system—or heats it to 40 °C to boost the hot-water system. Universities are ideal for such experiments. As autonomous public institutions they are exempt from fiddly local rules and from oversight by the utilities regulator. And they are interested in new ideas.

Places like UCSD not only save money with their micro-grids but advance research as well. A

server analyses 84,000 data streams every second. A company called ZBB Energy has installed innovative zinc-bromide batteries; another company is trying out a 28kW supercapacitor—a storage device far faster and more powerful than any chemical battery. NRG has installed a rapid charger for electric vehicles, whose past-their-prime batteries are used to provide cheap extra storage. And the university has just bought 2.5 MW-worth of recyclable lithium-ion iron-phosphate battery storage from BYD, the world's largest battery manufacturer, to flatten peaks in demand and supply further.

In one sense, UCSD is not a

good customer for the local utility, San Diego Gas & Electric. The microgrid imports only 8% of its power from the utility. But it can help out when demand elsewhere is tight, cutting its own consumption by turning down air-conditioners and other power-thirsty devices and sending the spare electricity to the grid.

UCSD is one of scores of such microgrids pioneering new ways of using electricity efficiently and cheaply through better design, data-processing technology and changes in behaviour. The IEA reckons that this approach could cut peak demand for power in industrialized countries by 20%. That would be good for both consumers and the planet.

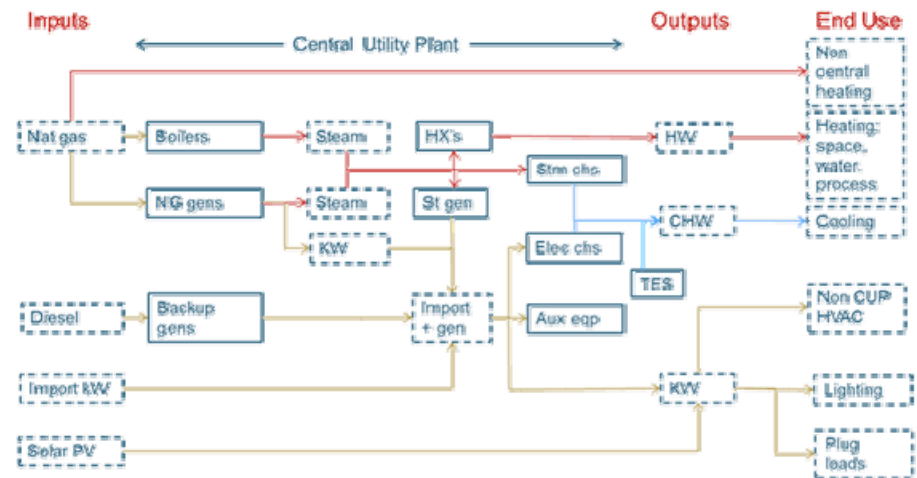

The CUP system generates 92% of the campus's electricity and saves \$8m a year.



## Remembering Mel Spiro

By **Robert K. Jordan**  
**Professor Emeritus of  
 Anthropology**

Our colleague **Mel Spiro** died on October 18 after a long struggle with esophageal cancer. He was an intellectually vigorous 94. A brief biography can be found on the Anthropology department's web page, and another on Wikipedia, of course. The latter tells the reader that "Spiro received his B.A. from the University of Minnesota, where he majored in philosophy, following which he studied at the Jewish Theological Seminary in New York City. Having developed an interest in culture theory, he explored this interest by enrolling in the anthropology department at Northwestern University, where he worked with **Melville Herskovits** and **A. Irving Hallowell**, and received his Ph.D. in 1950."

It goes on to mention that he taught briefly at Washington University and at the Universities of Connecticut, Washington, and Chicago and then came to UCSD in 1968 to found our department, to set its general intellectual direction, and to recruit our initial faculty and our first class of graduate students, who entered in 1969.

Mel was in fact recruited while spending a year at Hawaii's East-West Center, where he met fellow think-tankers **Bob Levy**, a New York psychiatrist writing up materials he had collected in Tahiti, and **Ted Schwartz**, a former student of **Margaret Mead's** who was engaged in a long-term, psychologically nuanced study of a New Guinea cargo cult. All three of them were concerned with the development and exploration of a psychologically informed anthropology.

When Mel was recruited to found the UCSD department, Ted and Bob were natural members of



Photo by Manny Rotenberg

the founding faculty. So was a former student of Mel's, **Marc Swartz**, whose interdisciplinary Harvard degree in Social Relations and fieldwork on family relations in Truk positioned him well for psychologically informed anthropology. Rounding out the initial faculty was **Joyce Bennet** (later **Justus**) a Jamaican graduate student working with Ted at UCLA, and myself, one of Mel's advisees at Chicago. I had just completed a dissertation on popular religion in Taiwan. (Ted's wife **Lola** worked with him in New Guinea, but the nepotism rules of the time precluded hiring her. She eventually joined the Department of Community Medicine and taught medical anthropology for many years.)

Mel had done early fieldwork in Ifaluk, a Micronesian atoll, and but was better known for his widely read work on the psychological world of the Israeli kibbutz. By the time he came to UCSD, he had already also undertaken his earliest work in Burma. Bob Levy, finishing his book on Tahiti, was gearing up to study Nepal. And **Marc Swartz** had already begun work in Africa, first among the Bena of Tanzania, later among the urban Swahili of Kenya. My work

remained in Taiwan, Joyce's in Jamaica, and Ted's in Melanesia. For a faculty of six, the geographical coverage was impressive, but what put the department on the map was obviously the focus on psychological perspectives in anthropology.

Soon we were joined by **Gananath Obeyesekere** and **Roy D'Andrade**, both psychological anthropologists, and by **Fred Bailey**, who always denied being a "psychological type" but could never quite shake the accusation of being a "psych-symp type," since his studies of charisma, leadership, and political relations inevitably involved him in the world of motivation.

The department has diversified since those days. We now also have archaeologists and specialists in linguistic, biological, and various flavors of not-particularly psychological cultural anthropology. I like to think that the "psych-symp" label characterizes all of my colleagues, however.

The reason is not far to seek. Mel's initial, and well shared vision saw motivation as a core problem in cross-cultural study. The famous mid-century nature-nurture discussions had long since run their interesting but somewhat indeterminate course, and Mel had successfully persuaded all of us that there was a third factor: "indirectly biological" universal features of human experience (in particular the experience of total dependency in childhood and the fact that mothers are always female).

Following his old teacher Hallowell, Mel explored the effects of infantile dependency, and the rage potentially generated by it, and the ways in which cultural practices operated as "culturally constituted mechanisms of defense." For example, rage may be harmlessly directed against evil spirits, or pro-

jected onto hypothetical monsters whom one must defend oneself against. Such a perspective has become a fundamental part of my understanding of how religion works. It is not something I learned in graduate school, but rather in the course of discussions with Mel here at UCSD.

In one article he laid out a matrix of orthogonal contrasts to look for in considering the functions of human actions: conscious-unconscious, intended-unintended, recognized-unrecognized, a scheme I find myself teaching to (puzzled) freshmen to this day.

One logical effect of seeing past nature-nurture to incorporate the universality of infantile dependency (or of female motherhood or of other experiential universals), is stark suspicion of claims of extreme cultural determinism, an intellectual fashion which rose (or returned) to prominence in some circles of anthropology and other fields late in Mel's career, and his later writings are often aimed at head-

ing off the fell consequences of a position that seemed to him to ignore basic human nature.

Mel was a focused and methodical thinker. Working in three ethnographic regions, he never let the minutiae of the regional specialists (the people he called the "ologists") deflect his attention from the psychodynamic issues he was intent upon exploring. As a graduate student I met such an "ologist" who was shocked that I was working with "that Spiro," clearly a lesser light because he had said there was no sorcery in Ifaluk (apparently because hostility was focused on demons rather than people), whereas she had found one elderly sorcerer there, thus proving that Spiro was clearly wrong, wrong, wrong! She had clearly failed to notice the big picture. She did not inspire generations of colleagues and students. Mel did.

In a department full of senior psychological anthropologists, I gravitated toward teaching our non-psychological courses, and as my career developed it would not be quite right for me to describe myself as a psychological anthropologist.

But I remain stubbornly a "psych-symp type," a title I owe to Mel, and bear proudly. I am not alone. If, among the alumni of our department, there are any who would not claim the same title, I am at loss to think of them.

**Afterword:** An excellent intellectual biography of Mel is Kevin Avruch's "Melford Spiro and the Scientific Study of Culture" in *Personality and the Cultural Construction of Society: Papers in Honor of Melford E. Spiro*. (Ed. by David K. Jordan and Marc J. Swartz. U. of Alabama Press. 1990), a volume which includes an ample bibliography. A convenient collection of papers is *Culture and Human Nature: Theoretical Papers of Melford E. Spiro*. (Ed. by Benjamin Kilborne and L.L. Langness. U. of Chicago Press. 1987.) A memorial event to honor Mel Spiro, founder of the Department of Anthropology, will be held in the Faculty Club Lounge at 2:00 on Sunday, April 19th.



## Joe Gusfield, Founding Chair of Sociology

**By Richard P. Madsen**  
Distinguished Professor of Sociology

**Joseph R. Gusfield**, internationally renowned sociologist and founding chair of UCSD's sociology department, passed away on January 5 at the age of 91.

Joe Gusfield was born in Chicago and attended public high school there before enrolling in the University of Chicago in 1941. He was the first in his family to attend college. After the outbreak of World War II, he served in the army for three years, and then returned to the University of Chicago, where he received both his



Photo by Manny Rotenberg

BA and 1954, his Ph.D. He expanded his dissertation into a classic book, *Symbolic Crusade: Status Politics and the American Temperance*

*Movement* (1963). In his analysis, social movements were as much about struggles for a particular version of moral order as about struggles for wealth and power. This work remains a foundation for the study of contemporary "culture wars."

He taught at Hobart and William Smith College and at the University of Illinois at Champaign-Urbana, and then in 1966, after 14 years at the University of Illinois, he was asked to be the founding chair of the UCSD sociology department. At first he turned the offer down. As he lat-

cont. on page 6 →

**Joe Gusfield**, *continued from page 5*

er recalled, UCSD “was a very small place then, mostly graduate studies, some undergraduates but not too many, and I thought a great deal about it and finally decided against it.” A year later, however, while on an exchange professorship in Japan, he received a phone call offering the position again, and he accepted. He joined the faculty in 1968. For sociology, he “wanted a department that would break with the emphasis on quantitative work. I wanted one that had much more of a concern with observation. I was also interested in historical sociology. I was interested in culture. . . . All these, in one sense or another, were part of what was going on in the intellectual work which was now called a cultural turn; moving towards a greater importance given to how the world is perceived and given meaning, rather than correlations between factors.” The distinctive strengths of the UCSD sociology department still

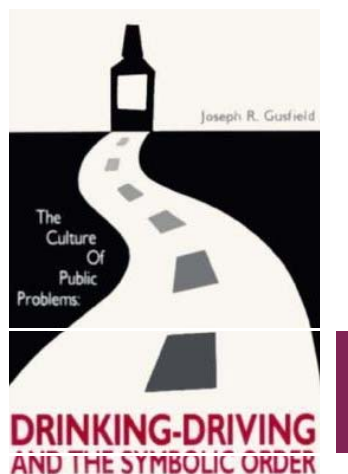

manifest the influence of his vision.

Soon after coming to UCSD, he undertook a study of sentencing in drinking and driving cases. This eventually culminated in another sociological classic *The Culture of Public Problems: Drinking, Driving, and the Symbolic Order* (1981). It was about the social and moral forces that led drunk driving to be a public problem and ultimately about the nature of the law as a symbol of what is good and moral in the particular contexts of American society. This book too remains a major point of reference for the sociology of law and the sociology of culture.

Joe’s sociological vision was inspired by activism and cross-cultural travel as well as scholarship. He was a sponsor for SNCC (the Student Non-violent Coordinating Committee) at the University of Illinois and participated in the civil rights march from Selma to Montgomery. (“I was considered an historian by that time and I marched with the historians as a group.”) He lived in India as a Fulbright scholar and taught for six months in Tokyo just before coming to UCSD. He wrote articles on the sociology of development based on his overseas research and long after his retirement in 1991 he continued to write about the sociology of law and deviance, addiction and its treatments, and the distinctive ways such issues are perceived in American culture.

Together with other colleagues

in UCSD’s founding generation, he played a major role in shaping the structure and standards of this institution. He did this not only through his wise judgment, but by his personal warmth and generosity of spirit. He and his wife, **Irma Gusfield**, provided countless hours of social support to generations of colleagues. Joe and Irma were perhaps the most socially active couple at UCSD. They were active in every imaginable activity: opera, concerts, cinemas, plays, baseball and football -- and horse racing. For Joe, it was essential to attend opening day at the races at Del Mar every season. The number of parties that Irma organized is impossible to tally. Irma was a medical social worker at the Children's Hospital and was always a special "consultant" for Joe and the many the academic issues he pondered. Joe was also an incredible storyteller, poet, and painter. His public lectures always included humor. His friends and students can be found all over the planet.

In retirement, Joe and Irma moved to Danville to be closer to their children in Oakland and Davis. There, Joe became a Distinguished Affiliated Scholar at Berkeley’s Center for the Study of Law and Society. Irma, his wife of 66 years, died in 2012. He is survived by his son **Dan**, daughter **Chaya**, and granddaughters **Yeshi**, **Talia**, and **Shira**; and daughters-in-law **Carrie Shepard** and **Judith Dambowic**. He was pre-deceased by his daughter **Julie**.

**An Electronic, or "E-Subscription" to the Emeriti Chronicles helps save the UCSD Emeriti Association money, and is environmentally-friendly.**

**If you would like to change your subscription from a print subscription to an E-subscription, please send an email to [Emeriti@ucsd.edu](mailto:Emeriti@ucsd.edu) with "Subscribe to E-Chronicles" in the subject line.**

**If you are already subscribed to E-Chronicles, no further action is necessary. Thank you for your contribution to our environmental sustainability efforts.**



## Anecdote

By Sandy Lakoff

### Department of Corrections:

Thanks to **Wayne Kennedy** and **Sidney Karin** for calling my attention to an erroneous report in this column. Our success in getting the Supercomputer Center was due to the efforts of **Dick Atkinson**, aided by **Kennedy, Bruce Darling**, and **Freeman Gilbert**; **Bob Dynes** later sealed the deal by getting the NSF to transfer operational control from General Atomic to UCSD.

\*\*\*

**Ward Elliott**, a political scientist at the Claremont Colleges, recently wrote to say that the historian **Niall Ferguson** was writing a book about **Henry Kissinger** and to ask what I might know about the influence of his father, **William Yandell Elliott**, on Kissinger's rise to power and fame. I did have a little story to tell of how Kissinger became the Machiavelli-an Realist of our time.

From the 1920s to the early 1950s, Elliott père was a formidable figure in the Department of Government at Harvard, when the faculty still resembled a system of feudal baronies. A courtly Southerner, he had done excellent work on political theory in his prime but had since become notorious for name-dropping and bouts of megalomania. (In a Gov 1 lecture one of the note-takers counted 50 instances in which he mentioned his ties to one or another Great Man. During the Korean War I heard him interject, out of the blue, "I told General **MacArthur** not to go beyond the Yalu ...")

But Elliot had an eye for talent and he saw that Kissinger had exceptional gifts, so he made sure he



was appointed to the junior faculty and assigned to run a summer school program that attracted many future world leaders. In return, Henry was more than deferential to his mentor and protector. Once a fellow grad student and I sat in on a seminar in which he was presenting a paper. "Henry," Elliott interrupted several times, saying something like "I want to flag that; I settled the issue in my book *The Pragmatic Revolt*." Each time, Kissinger would say, "Yes, sir, "I will footnote that." We were appalled at this toadying; but Henry knew what he was doing.

In the mid-50s, Elliott was the only Republican in the entire department, so when Governor **Nelson Rockefeller** needed an executive director for a study of nuclear weapons and strategy, he turned to Elliott, who recommended Kissinger. That later brought Henry to the attention of **Richard Nixon**, who named him his National Security Advisor when he became president in 1961.

Meanwhile as a junior member of the department I had gotten to know Elliott and to like him. One day I ran into him in Washington after Kissinger had been appointed by Nixon. I said

to him, "You must be very proud. All those years, when others may not have appreciated Henry, you saw his promise and nurtured him, and now he is a great success."

"Yes," he said, glowering, "and do you know what he's done?" "No," I replied, "what's that?" "He's given word," Elliott replied, "that I am not to be allowed into the White House to see the President!"

**Machiavelli** would have been even prouder of his pupil Henry.

\*\*\*

The death of the political scientist **Walter Berns** brought back memories. Berns and **Allan Bloom** had resigned from Cornell in 1959 in a protest against the administration's failure to punish a "black power" takeover of university buildings and had joined the department of political economy at the University of Toronto to which I had just been appointed. The leader of the protest later became head of the Teachers Insurance and Annuity Association (TIAA). The New York Times obit quoted Berns as writing to the one-time protest leader: "First you tried to kill me and now you want to care of me in my old age!"

Bloom had little money in those days but swell-elegant tastes. Every year he would add to his collection a piece of Georg Jensen silverware from the company's nearby shop on Bloor Street. One year he bought a large glass-domed butter dish and was showing it off to a group of students. "How do you like it?" he asked. "It's very nice," one of the students said, "if butter is your main course."

**UCSD Emeriti Association  
Annual Business Luncheon**

**Wednesday, June 3 Ω 11:30 AM - 2 PM  
Ida & Cecil Greene Faculty Club**

**\$25 per member, Non-members: \$40**

*Please mail your check to:  
UCSD Emeriti Association  
9500 Gilman Drive, Dept. 0020  
La Jolla, CA 92093-0020*



*James H. Mckerrow  
Dean of Skaggs School  
of Pharmacy &  
Pharmaceutical Sciences  
Topic: Tropical Diseases*

# Chronicles

Newsletter of the UCSD Emeriti Association



<b>Sanford Lakoff</b>	Editor (slakoff@ucsd.edu)
<b>Mel Green</b>	Assistant Editor
<b>Suzan Cioffi</b>	Layout and Design

**Officers**

<b>Joel Dimsdale</b>	President
<b>Henry Powell</b>	Vice President
<b>Phyllis Mirsky</b>	Secretary/Treasurer
<b>David Miller</b>	Past President, Awards

**Executive Committee**

<b>Joel Dimsdale</b>	President
<b>Henry Powell</b>	Vice President
<b>Phyllis Mirsky</b>	Secretary/Treasurer
<b>David Miller</b>	Past President, Awards

**Members at Large:** Robert Knox, Carol Plantamura, Morton Printz, Lea Rudee, Roger Spragg, Joe Watson. **Ex Officio:** Dick Attiyeh, Representative to CUCEA, Robert Hamburger, Historian, Nancy Groves, Representative, UCSD Retirement Association, Sandy Lakoff, Editor, Chronicles, Suzan Cioffi, Director, Retirement Resource Center, and Maxine Bloor, Liaison to Oceanids.

*Forward queries, changes in mailing/email address to:  
Suzan Cioffi, Director, UCSD Retirement Resource Center,  
UCSD, 9500 Gilman Drive, #0020, La Jolla, CA 92093-0020.  
Telephone: (858) 534-4724, Emeriti@ucsd.edu*

## Mark your calendar for 2015 events!



**Chancellor Emerita Marye Anne Fox**

*"California's Educational Edge:  
The Kerr Master Plan"*

**Wednesday, March 11, 2015, 3:30 - 5:00 PM  
Ida & Cecil Green Faculty Club**



**Albert P. Pisano, Professor and Dean  
UC San Diego Jacobs School of Engineering**

*"Engineering as a Force for the Public Good"*

**Wednesday, April 8, 2015, 3:30 - 5:00 PM  
Ida & Cecil Green Faculty Club**



**Frank Biess, Professor, Modern European History**

*"WWI and the Birth of the Modern World"*

**Wednesday, May 13, 2015, 3:30 - 5:00 PM  
Ida & Cecil Green Faculty Club**